

**MAKEEN
ENERGY**

FAS Autogas Technology

Safety - Quality - Reliability

A MAKEEN Energy Company

FAS
A MAKEEN Energy Company

LPG Dispensers

With the know-how of almost 50 years in the field of planning, engineering, and construction of LPG dispensers and Autogas Filling Stations, FAS has world-wide references with more than 13,000 manufactured dispensers. The electronic dispensers with complete hose system (single or double hose) and stainless steel housing are especially constructed for the discharge of LPG (propane/butane). They can be operated centrally as part of a petrol filling station or as an independent unit.

Key benefits:

- High precision, accuracy, reliability
- Long lifetime
- Low maintenance cost
- Different types of filling nozzles available
- Execution with piston or mass flow meter
- Hose retraction system
- All common dispenser computers available
- Connection to POS System
- Shear valves for essential increase of safety with vehicle contact
- Switch cabinet with remote access
- Stand-alone solution

Options:

- Different types of LPG dispensers
- Execution with supply or submersible pump
- Different sizes of LPG storage tank
- Different filling nozzles available
- Underground storage tank with submersible pump
- Execution with one or several storage tanks (Export)
- Weather protection roof

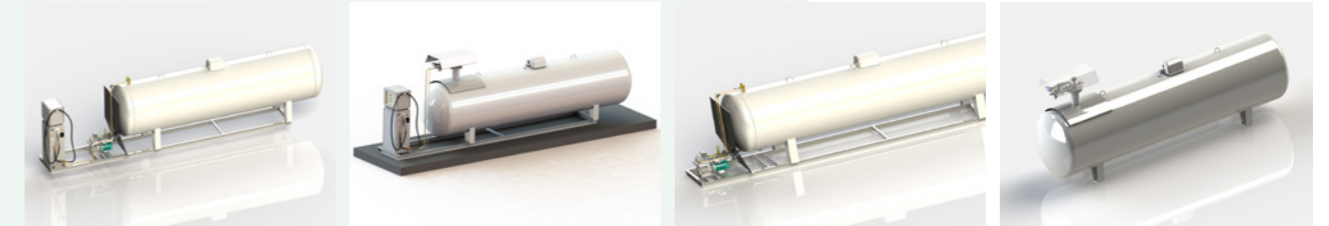

- with dispenser
- with supply pump unit
- with dispenser
- with submersible pump unit
- without dispenser
- with supply pump unit
- without dispenser
- with submersible pump unit

Compact filling stations

The compact filling stations are equipped with an above-ground tank and pressure increasing pump, with dispenser and optionally with weather protection roof. They include all required safety equipment and are mounted on a galvanised base frame, wired, piped, primed, and painted.

They are designed according to customer request and to local regulations.

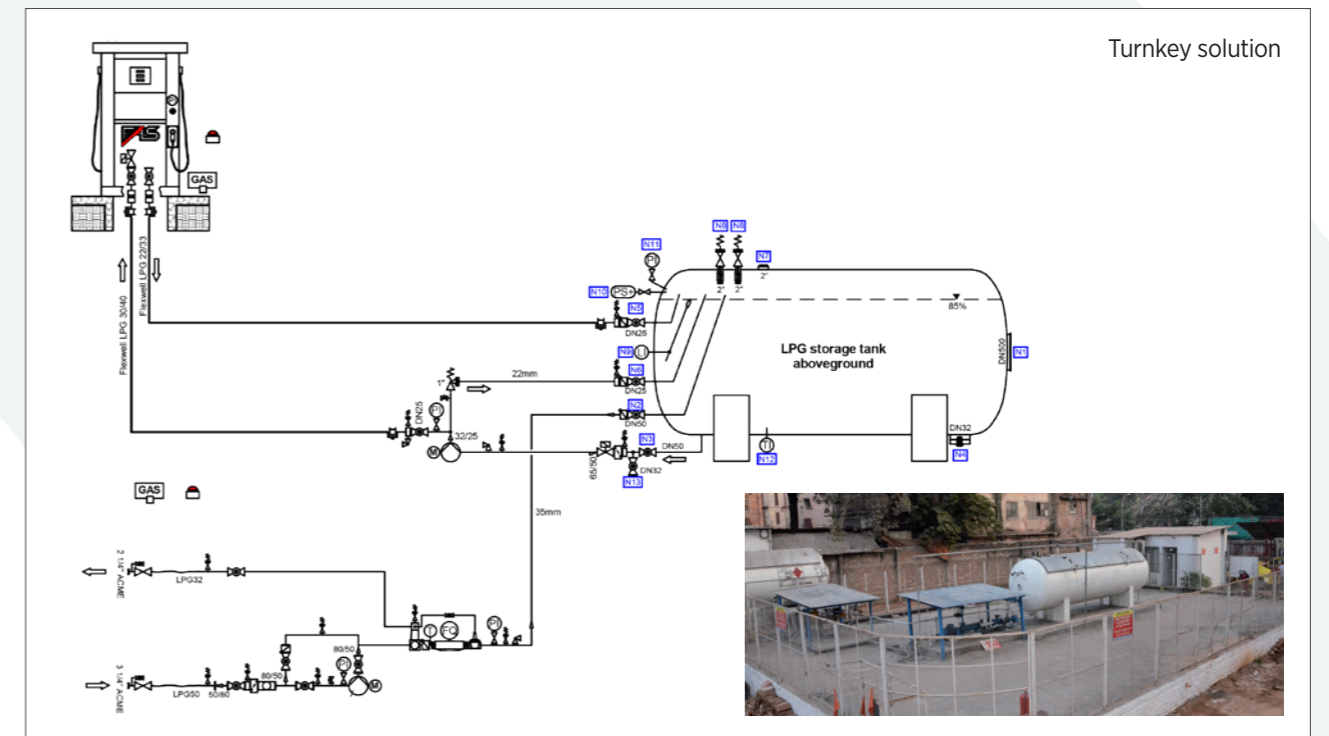

Internal LPG refuelling systems

Question of location

Certain safety distances and protection zones and specifications for protection against mechanical damage must be observed when determining the location for your internal LPG refuelling systems.

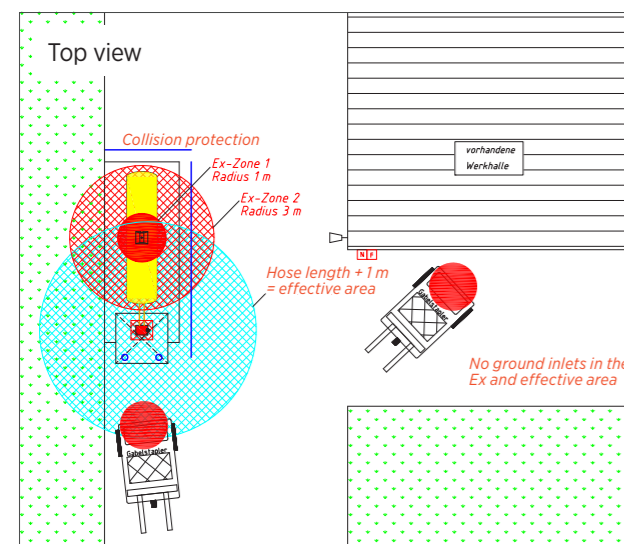
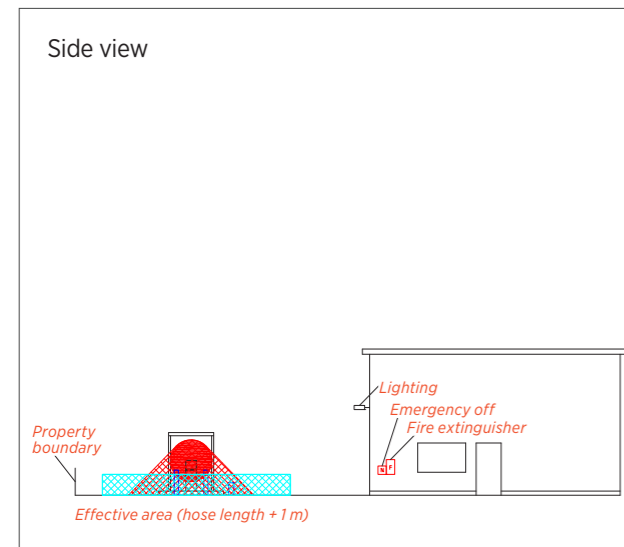

Basic execution without quantity recording

Execution with small dispensing device/dispenser FAS 130

- FAS dispenser with control system in head of dispenser
- Safety shear coupling underneath dispenser
- Optional refuelling release function via Transponder
- System control with LOGO! SPS control unit
- Combinable with supply or submersible pump
- Execution with several storage tanks (Export)
- Weather protection roof



Execution with dispenser type FAS 130, without quantity recording



Execution with small dispensing device, Compact filling station with supply pump

Basic execution with quantity recording

Execution with dispenser FAS 130

- FAS dispenser with control system in head of dispenser
- Safety shear coupling underneath dispenser
- Optional hose retraction system



Execution with mechanical resettable litre counter



Compact filling station with supply pump

- System control with LOGO! SPS control unit
- Combinable with supply or submersible pump
- Execution with several storage tanks (Export)
- Weather protection roof



Execution with mechanical non-resettable litre counter



Compact filling station with submersible pump

Executions with transponder release combinable with all types of FAS dispensers

- FAS dispenser with control system in head of dispenser
- Safety shear coupling underneath dispenser
- Refuelling release via transponder
- Optional hose retraction system
- Optional emergency refuelling switch
- System control with LOGO! SPS control unit
- Combinable with supply or submersible pump



Execution with dispenser FAS 130 with transponder

Execution with dispenser FAS 430L

- FAS dispenser with control system in head of dispenser
- Safety shear coupling underneath dispenser
- NFC multifunction reader for manual transponder
- Numeric decimal keypad
- Alphanumeric LC-Display, backlit
- Optional hose retraction system
- Optional release light
- Optional emergency refuelling switch
- Tank data readout via network connection
- Optional tank data transfer via short-range modem
- Optional automatic vehicle recognition via vehicle transponder
- System control with LOGO! SPS control unit
- Combinable with supply or submersible pump



Execution with dispenser FAS 430L

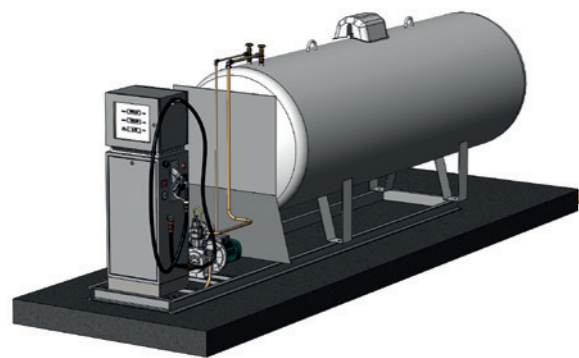

Scheme: Compact refuelling system with supply pump and aboveground storage tank

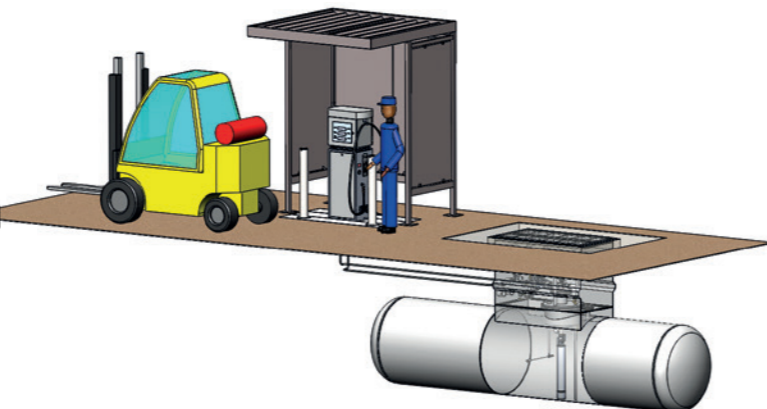

Scheme: Compact refuelling system with submersible pump and underground storage tank

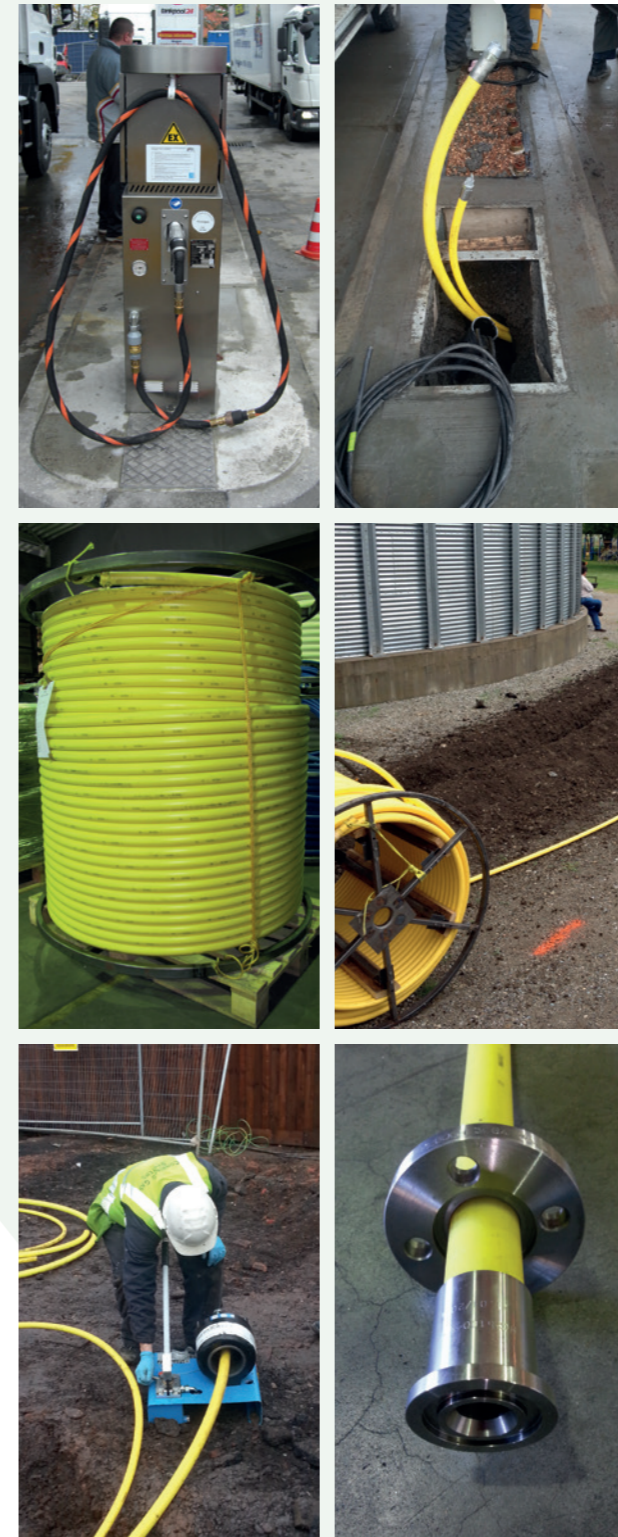

LPG-Flex® Pipe

The flexible pipes consist of an inner nylon jacket, a multilayered meshwork of aramid fibers (radial and longitudinal direction), and a coating of abrasion-proof polypropylene.

This construction offers a high stability and corrosion resistance with an operating pressure of up to 35 bar. The pipes are suitable for liquid and gaseous LPG, particularly for the underground connection e.g. for filling stations, tanks farms, and industrial plants.

The flexible pipe is rolled up for transport purposes and thus suitable for very quick and cost-efficient installation. Additional connecting pieces are not necessary. As the pipe shows a lower pressure loss than e.g. steel tube, the same flow rates are achieved with a smaller pipe diameter.

The pipes are available in nominal widths DN 20, DN 25 and DN 32.

Essential advantages:

- High stability and corrosion resistance
- Direct installation without additional connecting pieces up to 200 m
- Low pressure loss in comparison to other materials
- Nominal pressure 35 bar
- Easy, quick, and cost-efficient installation
- Long lifetime

MAKEEN ENERGY

Flüssiggas-Anlagen GmbH

Peiner Straße 217
38229 Salzgitter
Germany
Tel +49 5341 8697-0
Fax +49 5341 8697-11

info@fas.de
www.fas.de
www.fas-engineering.de

MAKEEN Energy

Alsvej 21
8940 Randers SV
Denmark
Tel +45 8740 3000

info@makeenenergy.com
www.makeenenergy.com
www.makeengasequipment.com

Follow us on:



MAKEEN Gas Equipment

offers a wide range of high-quality gas equipment and components along with expert guidance from the beginning to the end of your project. In that way, our one-stop shop philosophy – and many warehouses around the world – provides you with much more than just a product.

MAKEEN Energy is a global, market-leading corporation that delivers equipment, solutions and services to the energy industry. We employ approx. 4,000 people across over 140 countries. With our global reach, local presence and decades of experience, we can deliver responsible solutions that make a difference to people and planet.

Worldwide MAKEEN Gas Equipment contacts

Country	Tel
Denmark	+45 8644 8734
Germany	+49 5341 8697-0
Belgium	+32 1024 2000
Portugal	+351 220 938 677
UK	+44 (0) 1792 224000
USA	+1 800 821 1829
Brazil	+55 11 2446 4644
Bangladesh	+880 1313 444 833
India	+91 40 3502 3270
Indonesia	+62 21 5312 2308
Malaysia	+60 3 6274 8801
Saudi Arabia	+966 569 978 7053

Check makeengasequipment.com/locations for more details on your local MAKEEN Gas Equipment contact

